

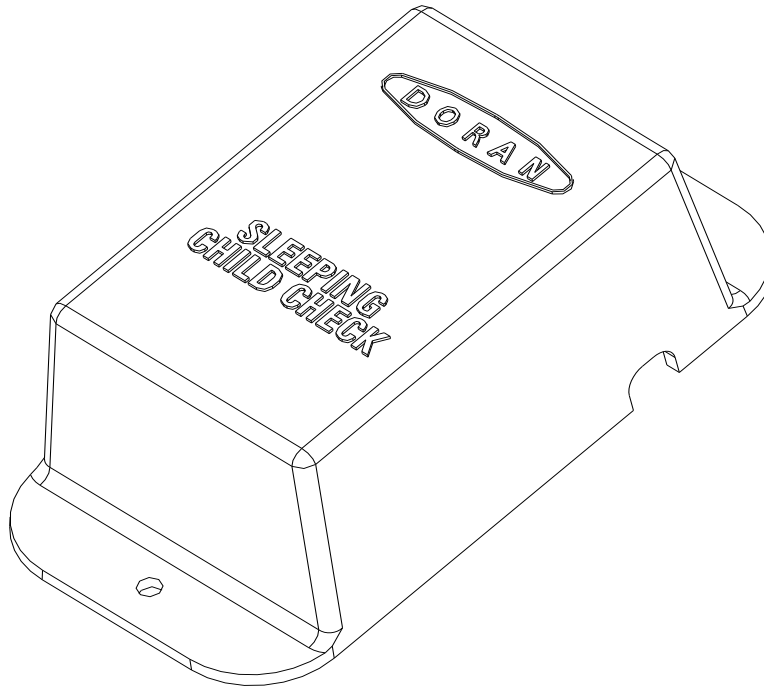

SLEEPING CHILD CHECK

*Model SCC-AM-00/01 and
Model SCC-AM-24V*



INSTALLATION AND OPERATION MANUAL

Doran Manufacturing LLC
2851 Massachusetts Ave.
Cincinnati, Ohio 45225
(866)-816-7233 TEL
(513) 681-5604 FAX
www.doranmfg.com

OCTOBER 2016

DORAN MFG LLC SLEEPING CHILD CHECK

HOW IT WORKS

Doran Manufacturing's Sleeping Child Check (SCC) is an electronic device that, when armed, is designed to force the bus driver to walk to the back of the bus and de-activate the system before leaving the vehicle. If the driver fails to do so, and exits the bus through the front door, the horn will immediately sound.

Doran designed this unique system with the children's safety in mind. Leaving a child on an empty school bus at the end of a route would create a nightmare for the youngster, his family and the school district.

Doran's Sleeping Child Check gives you the peace of mind in knowing that the bus driver cannot deactivate the system without first walking to the back of the bus - virtually eliminating the possibility that a child will be left behind.

1) What is included?

- Doran Mfg. Sleeping Child Check module (1)
- Re-set Switch (1)

2) What you will need:

- Wiring Instructions- find online at www.doranmfg.com
- Electric drill and 5/8" drill bit
- Test Light Probe.
- 16 or 14 gauge wire, Automotive GXL, SLX or equivalent
- Insulated female quick-connectors for .250" blades
- Wire stripper/crimper
- Basic hand tools
- Wire ties
- Automotive-grade insulated wire splices or equivalent
- Loctite® (non-permanent, serviceable) or equivalent
- (2) # 10 self tapping screws
- **SCC-AM-SW-00 switch (see page 11 of this manual to determine if it is required for you application)**
- **Optional if needed (Additional isolated door jam switches for Conversion vans and Mini buses)**

These are considered general instructions for the Sleeping Child Check module. To ensure proper and reliable function of this product, the Sleeping Child Check must be installed according to the directions. Some variation may be required depending on the manufacturer of your specific bus. Contact Doran Manufacturing or visit our website at www.doranmfg.com for questions or comments regarding these instructions.

Please follow the testing procedure upon completion of installation of the Doran Sleeping Child Check listed on page 10 of this manual.

TYPICAL WIRING CONNECTION TO SCC MODULE

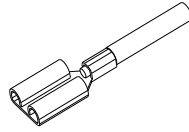

Fig. 1
Insulated female Quick-Connector for .250" wide blades crimped to 16-gauge wire.

SLEEPING CHILD CHECK WIRING OPTIONS

(12V SCC Model pictured)

Option #1

Chassis Ground – When grounded, horn sounds immediately upon probing

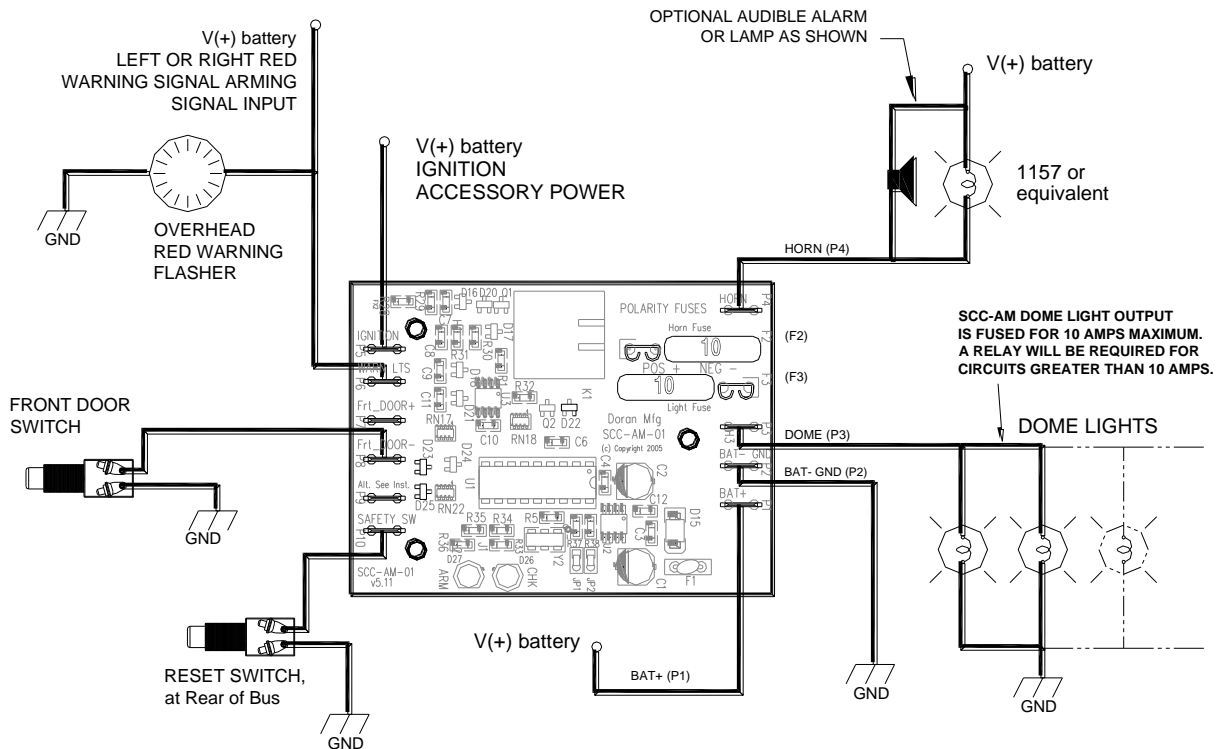

(See Section III for detailed wiring instructions)

Option #2

Horn sounds when connected to Positive(+) V

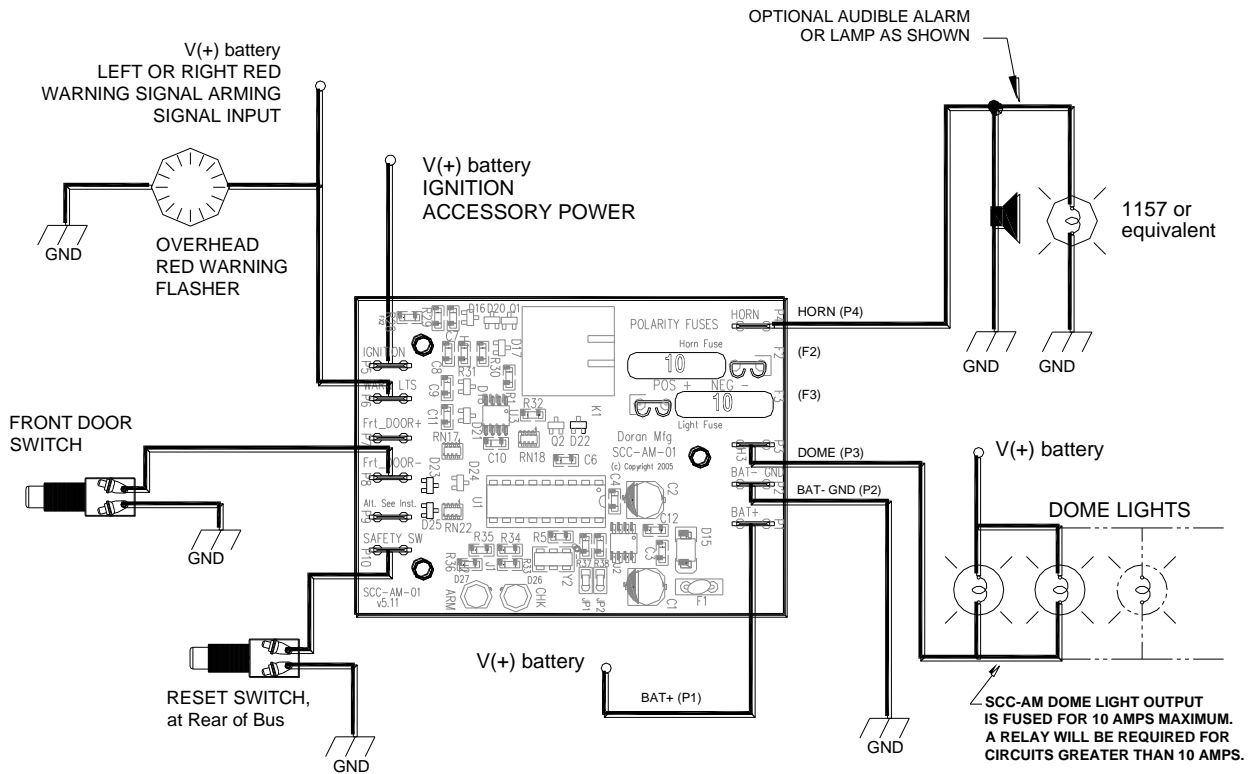

Option #3

CONVERSION VANS / MINIBUSES

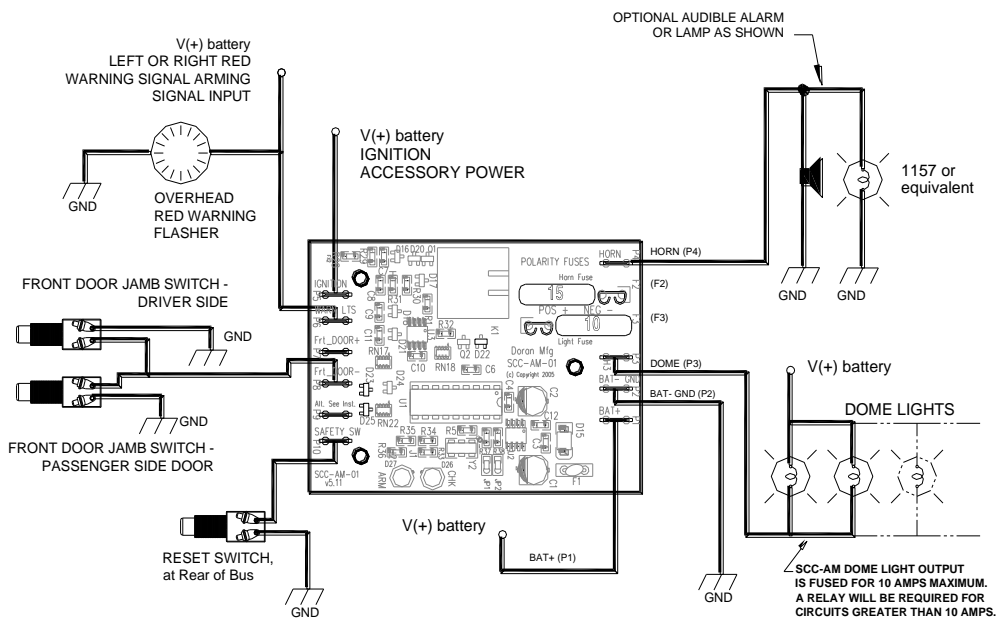

(See Section III for detailed wiring instructions)

INSTALLATION INSTRUCTIONS

I. Physical Installation

Locate the module where it is convenient to access most of the signals in the list below. Make sure that it does not interfere with the driver's ability to control the vehicle. Electrical connections are made with insulated female quick connect terminals for .250" blades. Don't permanently mount the module until the connections and testing are completed.

Connections List

- P1 – Constant Battery +, Connect to fused (10-15A) un-switched Battery Positive
- P2 – Battery Ground –, Connect to un-switched Battery Negative or Common
- P3 – Interior Passenger Lights Control
- P4 – Horn Control
- P5 – Ignition / Accessory Input
- P6 – System Arm Input
- P7 – Front Door +
- P8 – Front Door –
- P9 – alternate to shared P8 connection through isolation diode- not usually used, see troubleshooting section and figure 6.
- P10 – Safety, System Reset

II. Basic Operation

Inputs

P1 & P2:

The SCC requires constant battery power. When inactive (sleep mode), the unit draws less than 3 mA (0.003A) from the battery.

The fuses on the module protect the relays and the load, and also limit current through BAT+ and BAT-. But if both fuses are in the NEG- position, then the sum of load currents flows through P2 (BAT-) wiring. If both fuses are in the POS+ position, then the sum of load currents comes from P1 (BAT+).

Select the battery wire sizes and/or fuse accordingly.

P5 – Connect to Ignition or Accessory

P6 – Connect to an ARM signal, see instructions below.

P7 & P8: - Use either P7 or P8 or both to signal Front Door open

P7 – Connect to a Front Door signal that goes to battery voltage when the door opens.

P8 – Connect to a Front Door switch terminal that grounds when the door opens.

P9 – Usually not used, if there is a problem, see troubleshooting section and figure 6.

P10 – Connect to a dedicated Safety System Reset push button at the rear of vehicle.

Outputs

P4 – Horn control, relay contact to either Battery POS (+) or Battery GND (-).

P5 – Interior coach light control, relay contact to either Battery POS (+) or Battery GND (-).

The Polarity Fuses on the module select the choice of relays 1) grounding contact or 2) battery positive contact. The choice depends on control voltages needed to activate the horn and light.

Arming

To ARM the SCC and activate the system, a positive battery voltage signal must be detected at the ARM (P6) terminal with the Ignition on. An example signal to ARM the unit is the voltage for the Red Warning lights on the top of a bus or the control voltage for the Stop Arm Sign. Typically these are activated by a front door switch when the door is opened to load or unload students/passengers. It only takes one event to ARM the SCC. Once armed, the module will have to be reset via the Safety Switch input, either before the alarm goes off or after.

No Warning Lights

When a vehicle does not have warning lights, etc., it is still necessary to ARM the system to activate the required end-of-trip check. Often the Ignition signal or brake signal is used to ARM the module in this circumstance. It does mean however, that every time the vehicle is ARMED with ignition, the SCC system will require deactivation at the end of the trip. (See "Timer Options" for another alternative.)

For testing and trouble shooting, when the SCC is in ARMED state the Yellow LED is illuminated on the printed circuit board.

Safety System Alarm and System Reset/Deactivate

At the end of the trip, the ignition input will be turned off. If the system is ARMED, the overhead passenger light relay turns on indicating the vehicle must be checked and SCC deactivated before exiting. This output may also be used for a remote visual or audio indicator/reminder for the driver/operator. (See figure)

Example of External Check Bus Indicator

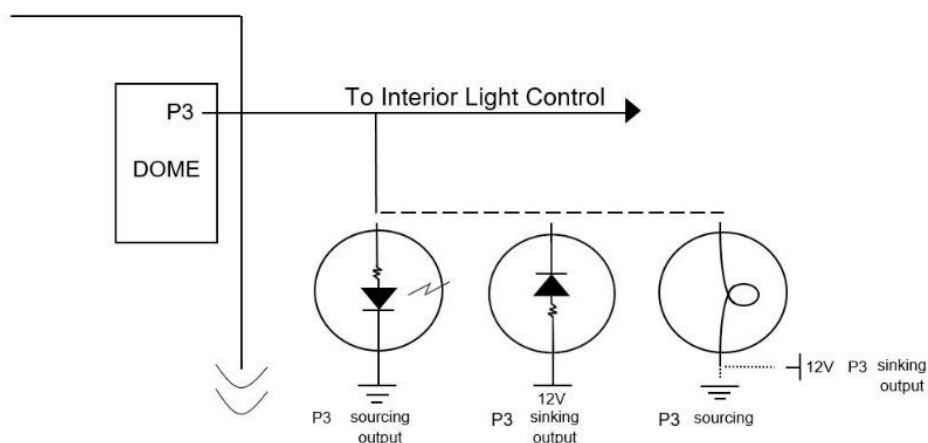

The front door input(s) must remain in the "door closed" condition or state to deactivate the system by pressing and releasing the reset push button at the rear of the vehicle. This is required either with or without the ALARM active. If the monitor is not in the ALARM state, the interior light relay will flash the lights twice to indicate successful deactivation, and then remain on for 1 minute. If the ALARM has been triggered,

successful reset will turn off the ALARM output and the interior light control will remain on for 1 minute.

If the ALARM has not been triggered, the ignition input (or alt. accessory input) may be turned on and the SCC will return to the ARMED state, interior light relay opens and front door may be open and closed without triggering ALARM.

For testing and trouble shooting, when system is ARMED with the ignition input off, the SCC is in "Check Vehicle" state and the Red LED on the printed circuit board will be flashing.

With the ignition (or alt. accessory) input off and monitor ARMED and if front door(s) is opened before SCC Reset is pressed, the horn output signal will begin cycling on and off. This will continue until the door(s) is/are closed and the SCC Reset button is pressed and released.

For testing and trouble shooting, when the SCC is in ALARM state the Red LED on the printed circuit board is illuminated and not flashing.

III. Wiring Instructions

POWER - P1 (Battery +)

Make a connection from **P1** ("Bat +" terminal on the SCC) to constant Pos(+) battery voltage. With the ignition turned OFF, use a test probe to locate a wire with constant positive voltage(+).

GROUND - P2 (Battery -)

Make a connection from **P2** ("Bat -" terminal on the SCC) to a chassis ground.

HORN - P4 (Horn Out)

Make a connection from **P4** ("Horn" terminal on the SCC) directly to the horn relay wire. This wire will output Pos (+) V or ground signals to energize the school bus relay.

To test if the horn is activated by a Pos (+)Vbattery or ground connection, locate the horn wire (usually found at the base of the steering column). Follow these steps:

- a) Connect the alligator clip on the test light probe to any metal surface that is a chassis ground.
- b) Probe the wire you believe carries the horn signal with the test light probe. Do not press horn button.

Option #1~ Chassis Ground Horn Activation

If the horn sounds immediately upon probing, you have found the correct wire. This may cause the test light to be dimly lit. If you press the horn button and the light goes out, you can be certain that the horn is activated by the ground signal. **The Horn Fuse (F2) should be in the NEG- Polarity position.**

Option #2~ Pos (+) V Battery Horn Activation (most common)

If you find a wire that lights up the test light when the horn button is sounded, you have most likely found the correct wire and can be fairly certain that it requires Pos(+) V to activate the horn. **The Horn Fuse (F2) should be in the POS+ Polarity position.**

Horn Fuse Position

Option #1 Ground Activation	Option #2 Battery + Activation
Fuse (F2) to NEG-	Fuse (F2) to POS+

Accessory or Ignition Power - P5 (Ignition)

Make a connection from **P5** (“Ignition” terminal on the SCC) to accessory power. To determine if the accessory wire receives Pos (+) V, turn the ignition key to the “ON” or “ACCESSORY” position, and probe the wire. The test light should come on. Turn the ignition key “OFF” and the test light should turn off.

Arm Input - P6 (Warning Lights)

Make a connection to **P6** (“Warning LTS” terminal on the SCC) from either the left or right overhead red warning light output wires from the flasher unit. If Warning Light signal is not available, see p6 “ARMING”.

Door - P8 (Frt_Door -)

A. STANDARD CONVENTIONAL BUSES:

Make a connection from **P8** (“Frt_DOOR-” terminal on the SCC) to the Front Door Switch. A convenient place to connect to the switch may be at the flasher unit, which uses the door switch. Frt_DOOR- is expecting a ground when the door begins to open. Frt_DOOR+ pin **P7** may be used if Bat(+)V is present when the door is opened.

B. CONVERSION VANS / MINI BUSES:

Buses with multiple (front) door exits, such as conversion vans or minibuses, require the SCC’s P8 terminal to be connected to both the driver side and passenger side front door switches. In some cases, additional doorjamb switches (normally closed) may be required for one or both front doors. Select a doorjamb switch (SPST - normally closed) that is compatible with the bus and properly mount in the doorjamb. Open and close the door to make sure the switch is operating and make any necessary adjustments to ensure proper switch operation. Wire pin P8 of the SCC-AM to one side of the switch, the vehicle’s chassis ground to the other side. For the schematic, please refer to WIRING OPTION 3 in SECTION I of this manual. Doorjamb switches are readily available and can be purchased at most auto-parts stores.

Reset Switch - P10 (Safety Switch)

Make a connection from **P10** (“SAFETY SW” terminal on the SCC) and run the wire to the rear interior of the bus where you plan to mount the reset switch. To mount the reset switch, refer to Section III, “Reset Switch Installation.”

Interior Overhead Light – P3 (Dome)

In some vehicles the interior lights may be controlled by vehicle electronics. In these vehicles it may not be possible to use the SCC's DOME light control. If there is a Grounding or Bat+ voltage control that activates the interior lights, it may be possible to parallel the SCC with the control or possibly by supplying Bat + voltage to an aux. relay or supplying Bat + to a light string, etc. Consult manufacturer's service representatives for assistance.

A. STANDARD CONVENTIONAL BUSES:

The SCC-AM module is configured to turn on the vehicle's interior overhead lights to aid the driver in inspecting the bus as the driver walks to the rear of the bus and back. The interior overhead light function is fused at 10 Amperes and can source or sink current depending on the position of the fuse. If the interior overhead lights draw more current than the fuse/relay can handle, an additional relay or relays can be used to increase the current capacity. (See **Figure 2**).

To use this feature, you will need to determine how the manual switch activates these lights. Find the wire going to the lights from the switch. With a test light or buzzer check the voltage to the light string from the switch outside. Using the following table, determine if the switch is sinking/grounding or sourcing the lights.

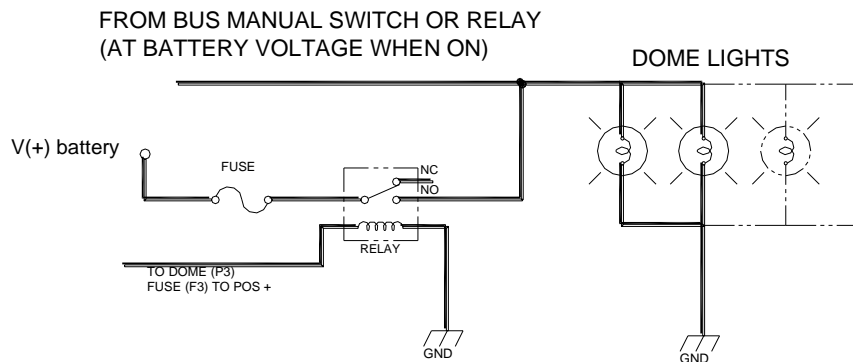

FIGURE 2

Example of using an auxiliary relay for high current capability.

Overhead Light Test

	Grounding (F3 to NEG-)	Sourcing (F3 to POS+)
Light Switch Off	Buzzer/Light On	Buzzer/Light Off
Light Switch On	Buzzer/Light Off	Buzzer/Light On

Move the 10 Amp. Light Fuse (F3) to indicated position (See Table). Wire terminal P3 from the SCC to the circuit connected to the interior overhead light switch.

B. CONVERSION VANS / MINI BUSES:

To use the interior overhead light feature with vans, it is important the door switch circuit and interior overhead light circuits are isolated from each other. For example, if the door switches directly ground the dome lights to make

them come on, then the relay in the Sleeping Child Check will ground the dome lights exactly like the doors. At the input to the SCC FRT DOOR- this would indicate a door has opened and trip the alarm when the ignition is turned off. For this condition, it will be necessary to install separate door switches for the Sleeping Child Check or not use/wire the overhead light feature.

Figure 3 shows an example of a relay isolated circuit like may be found on some vans. The polarity fuse position is determined the same way as described for a standard bus, see A in Interior Overhead Light section above.

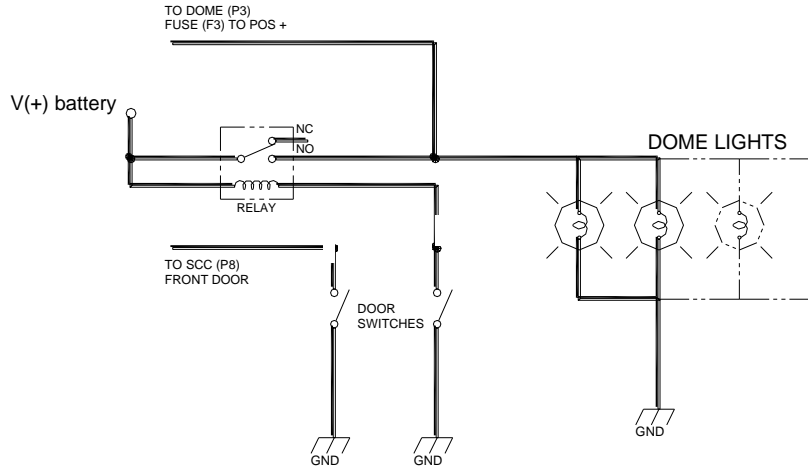

FIGURE 3
Example of relay isolated Dome Lights and Door Switches

C. CONVERSION VANS / MINI BUSES W/O WARNING FLASHERS

- Use ignition/accessory or brake light input at the ARM terminal P6. This usually means the system will need to be reset after any startup.
- Where driver usually must exit through driver door instead of passenger door, use end of trip 1 minute timer option as ALARM delay to allow the driver to reenter vehicle, check that the vehicle is empty and reset the monitor.
- A 10 minute ARM timer option may be used with or instead of a typical ARM signal. For cases / situations where the typical ARM signal is not available or used, an optional 10 minute timer will ARM the monitor after 10 minutes with the ignition/accessory on.

IV. Reset Switch Installation

The Reset switch (**Figure 4**) included with the Sleeping Child Check will need to be installed in the rear interior of the school bus. Be sure there is adequate access space behind the chosen location before installing the switch. An electric drill and 5/8" drill bit are required for installation.

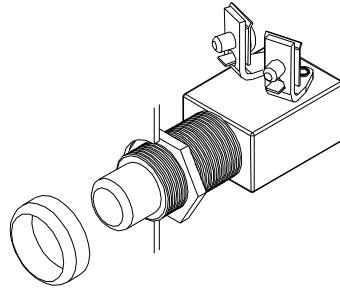

Figure 4

Cut-away view of Reset Switch Installation

- Drill 5/8" hole in access panel in the rear interior of the bus.
- Thread hex nut onto threaded stem.
- Insert switch through hole as shown.
- Adjust hex nut to proper depth to secure switch properly.
- Make a connection from chassis ground (at the rear of the bus) to one terminal of the reset switch.
- Make a connection from P10 wire to the other terminal of the reset switch.
- Apply Loctite[®] (non-permanent, serviceable) to exposed threads.
- Thread cap onto threaded stem and tighten securely.

V. Installation Testing for the SCC Monitor

The inspection procedure listed below should be followed at the completion of the installation.

- 1) Start the school bus. Make sure all the doors are closed.
 - 2) Activate the Red warning light flashers and open the door. The "YELLOW" LED will light on the circuit board to show the system is armed.
 - 3) Turn off the Red warning light flashers and close the door.
 - 4) Turn the ignition key to the "OFF" position. The "RED" LED will blink and the interior overhead lights will come on (if the overhead light option is hooked up)
 - 5) Open the front door. The "RED" LED will stay on and the horn should cycle on and off.
 - 6) Close the front door and walk to the back of the bus. Depress the reset switch. If functioning properly, this will disarm the Sleeping Child Check module and the horn should deactivate. Both LEDs will go out on the printed circuit board. The interior overhead lights will remain on for one minute if this option is installed.
- NOTE: (alarm will not deactivate with front door open).**

VI. Air Door Switch option #SCC-AM-SW-00

This option is required for buses equipped with power-assisted doors whose 8-way warning lamp flasher units are not activated by a mechanical door switch. For these buses, the SCC monitor will not function when the emergency release valve is used to dump the air from the system. To determine if this switch option will be required please perform the following procedure:

- Turn the ignition ON.
- Close the front door.
- Activate the Amber warning lights.
- Open the front door's emergency release valve to dump the air from the system.
- Walk over to the front door
- Manually push the front door open.
- Walk to the outside of the bus and check to see if the Red warning lights have been activated.
- If the Red warning lights are not flashing, then the air door switch option #SCC-AM-SW is required (**Figure 5**)

If the SCC-AM-SW-00 switch is required to be installed, please follow the instructions below:

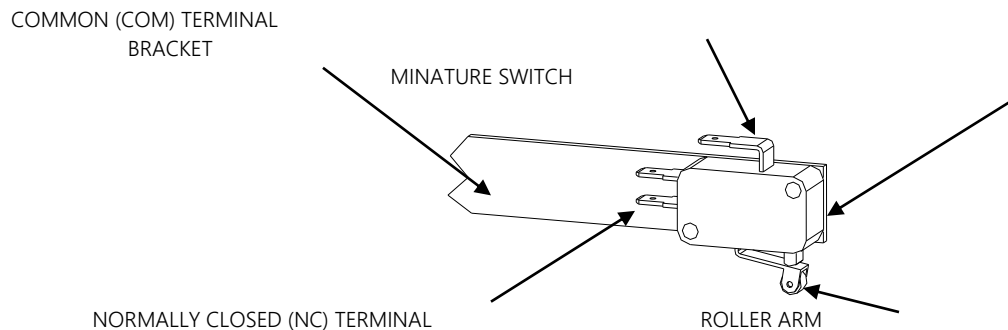

Figure 5

SCC-AM-SW-00 Switch

- Remove the panel above the air door.
- Bend and/or twist the switch bracket and firmly mount the SCC-AM-SW-00 switch assembly in a position where the switch's roller arm is fully engaged when the air door is fully closed. Excessive force applied to the switch's roller arm can cause damage to the switch. Because of this, the switch bracket should not deflect more than 1/32" when the roller arm is fully engaged.
- Connect the switch's common (COM) terminal to the SCC monitor's front door terminal #P8.
- Connect the switch's normally closed (NC) terminal to a chassis ground.
- Close the door and inspect the switch making sure the switch's roller arm is completely engaged.
- Open the front door and inspect the switch. The switch's roller arm should spring back to its original resting position.
- Follow the procedure in **SECTION V** to test the air door switch. This will ensure that it is functioning properly.

VII. Periodic Testing for the SCC Monitor

The inspection procedure listed below should be followed at the completion of the installation, and periodically to ensure the SCC is functioning properly.

1. Start the school bus. Make sure all the doors are closed.
2. Activate the Red warning light flashers and open the door.
3. Turn off the Red warning light flashers and close the door.
4. Turn the ignition key to the "OFF" position.
5. Overhead dome lights should come on if option is hooked up.
6. Open the front door. The horn should cycle on and off.
7. Close the front door and walk to the back of the bus. Depress the reset switch. If functioning properly, this will disarm the Sleeping Child Check module and the horn should deactivate. **NOTE:(alarm will not deactivate with front door open).**

VIII. Timer Options

Two (2) timer options are available, 1) a 10 minute ARM timer and 2) a 1 minute ALARM (Horn) timer.

Timer ARM Mode

The ARM Timer causes the module to ARM when the IGNITION/ACCESSORY input (P5) is active continuously for 10 minutes. The module may also be ARMED the usual way by a Battery Voltage signal on the ARM terminal (P6) if it is connected.

Some states require an additional way to ARM the module for field trips, shuttles and other group trips when the warning lights may not be activated during loading or unloading. Activating or ARMING the module after 10 minutes of travel or engine idling is acceptable.

The ARM Timer options might be used with vehicles such as vans that don't have warning lights, or other means to indicate passengers are boarding, and as an alternative to ARMING by ignition on.

Timer ALARM Mode

The ALARM Timer triggers the ALARM output 1 minute after the IGNITION input is turned off when the monitor is in an ARMED state. If a Front Door input(s) is connected, opening the door will still trigger an ALARM. The doors must be closed to deactivate the monitor.

This timer mode allows a maximum of 1 minute to deactivate the monitor before an ALARM is triggered. Some states require the 1 minute maximum deactivation time.

When it is necessary that the driver open his door and enter the vehicle by another door, this could be an alternative method to assure a vehicle is checked at end-of-trip by depending on the ALARM Timer to trigger the HORN ALARM after a 1 minute delay and don't connect/use the P7 or P8 door input(s).

*These two (2) timer modes are independently enabled. The Doran Sleeping Child Check (SCC-AM) may be ordered with options already enabled. Or users may enable timers themselves; however some disassembly may be required to properly access the programming jumpers. **If damage occurs from this procedure, Doran will not warrant the product.***

Selecting Timer Options

Jumper

- JP1* Open/cut JP1 for Horn ALARM to be triggered 1 Minute after Ignition Off
- JP2* Open/cut JP2 will ARM module after 10 continuous minutes with Ignition Input On. The module may be ARMED either way when P6 is used in this mode.

*Note: For the 24 volt model, pcb versions before 1.11, the instructions for JP1 and JP2 are reversed due to mislabeling. Pictured is the 12 volt model.

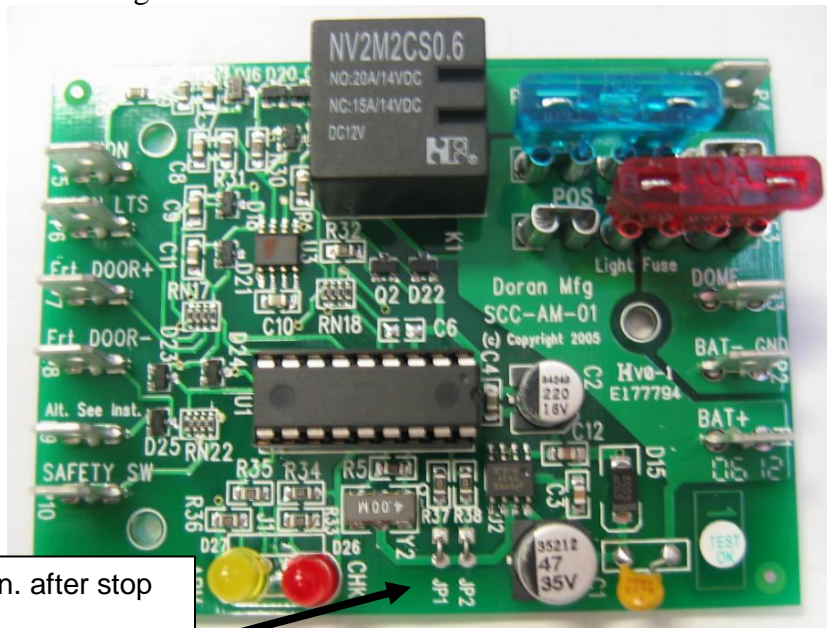

Open JP1 for 1 Min. after stop ALARM timer.
Open JP2 for 10 Min. ARM timer.

IX. Troubleshooting

Problem

Solution

Horn does not activate when I turn off accessory power and open the front door, but I can hear a relay inside the SCC module clicking on and off.

Check the connection on the horn relay wire. Verify that you have made a secure connection.

Horn does not activate when I turn off accessory power and open the front door, and I do not hear any relays clicking inside the SCC module.

If the front door switch is activated +12V/+24V at the output, the door switch wire should read "0" Volts when the door is closed, and +12V or +24V when the door is open, then P7 on the SCC should be used. If the front door switch grounds the switch output, the door switch wire should read +5 to +12V/+24V when the door is closed, and "0" Volts when the door is open. In this case the door switch wire should be connected to P8.

Horn activates immediately when the ignition/accessory switch is turned off.

(1.) Sometimes another device is connected to the same door switch and it "grounds" the SCC door input through "leakage" when the power is off to the device (sometimes the flasher unit will cause this). In this case the SCC door input must be isolated from the other device(s), or a separate door switch or contact must be used for the SCC. A diode has been provided on the SCC that may provide isolation from the other device. (See Fig. 6)
After the grounding door switch is directly connected to the SCC, connect the other device (flasher) to P9. Retest the operation of each device, as the device attached to P9 will not go completely to 0V when the door switch is grounded.

(2.) Door Switch is wired in conjunction with dome lights and a (new) door jamb Switch is required to activate SCC-AM properly

(3.) Check that door is not open or ajar causing the system to go into warning mode

Horn does not activate when I turn off accessory power and open the front door, and I do not hear any relays clicking inside the SCC module.

Check that the monitor has been ARMED. The yellow LED should be illuminated. If not illuminated, check ARM input (P6) "Warn LTS" that must receive a Bat + logic high after the ignition input is on.

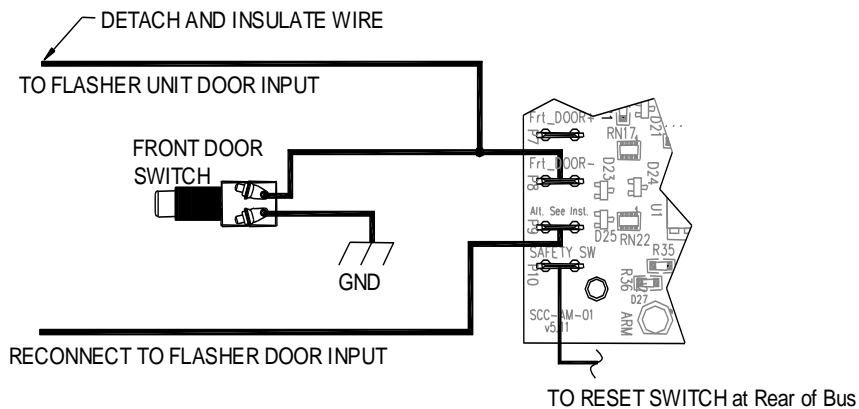

FIGURE 6